

CREATED ON 06/17/2024, LAST MODIFIED ON 12/17/2024

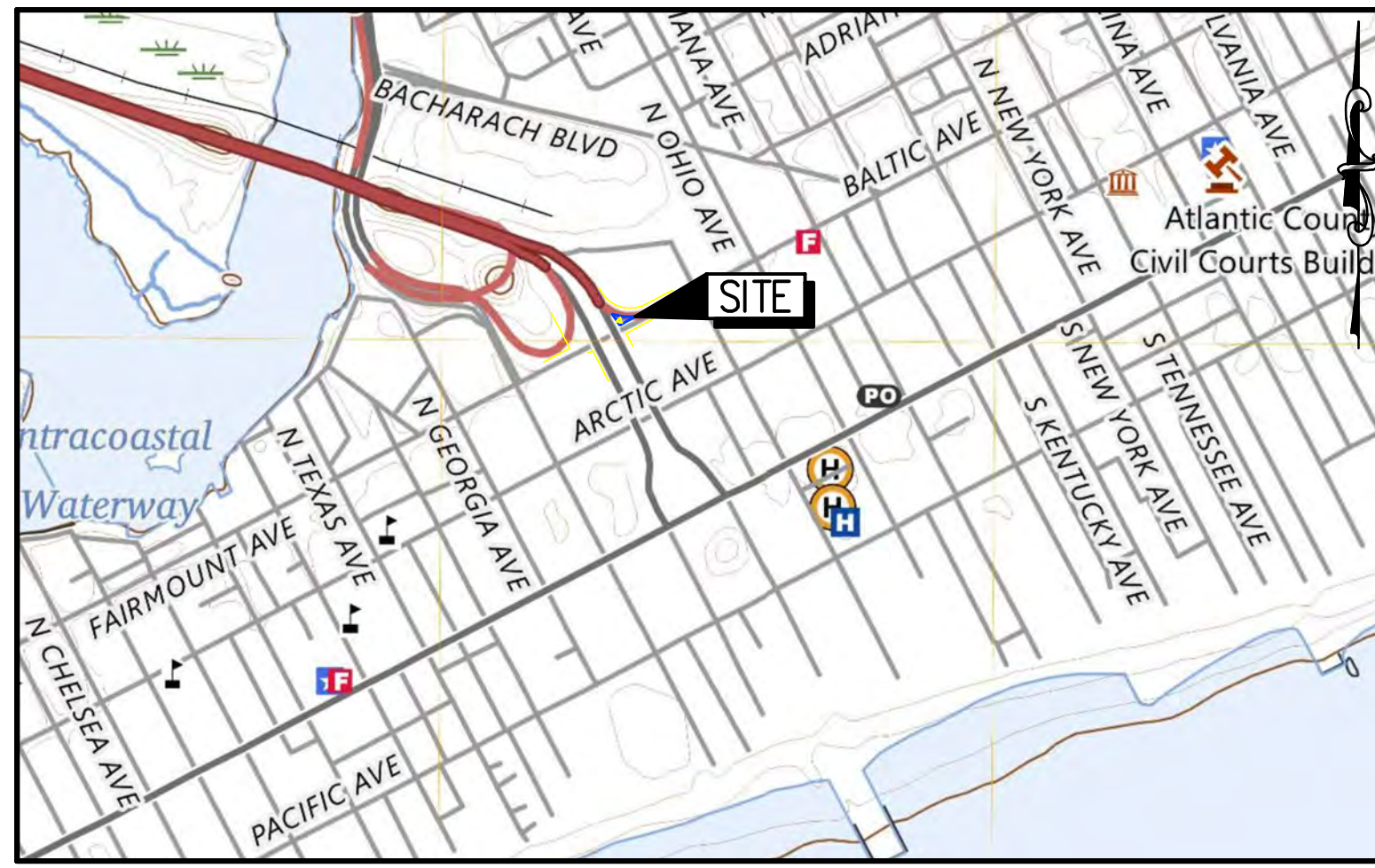

U.S.G.S. ATLANTIC CITY QUAD SHEET LOCATION MAP

SCALE: 1" = 1,000'

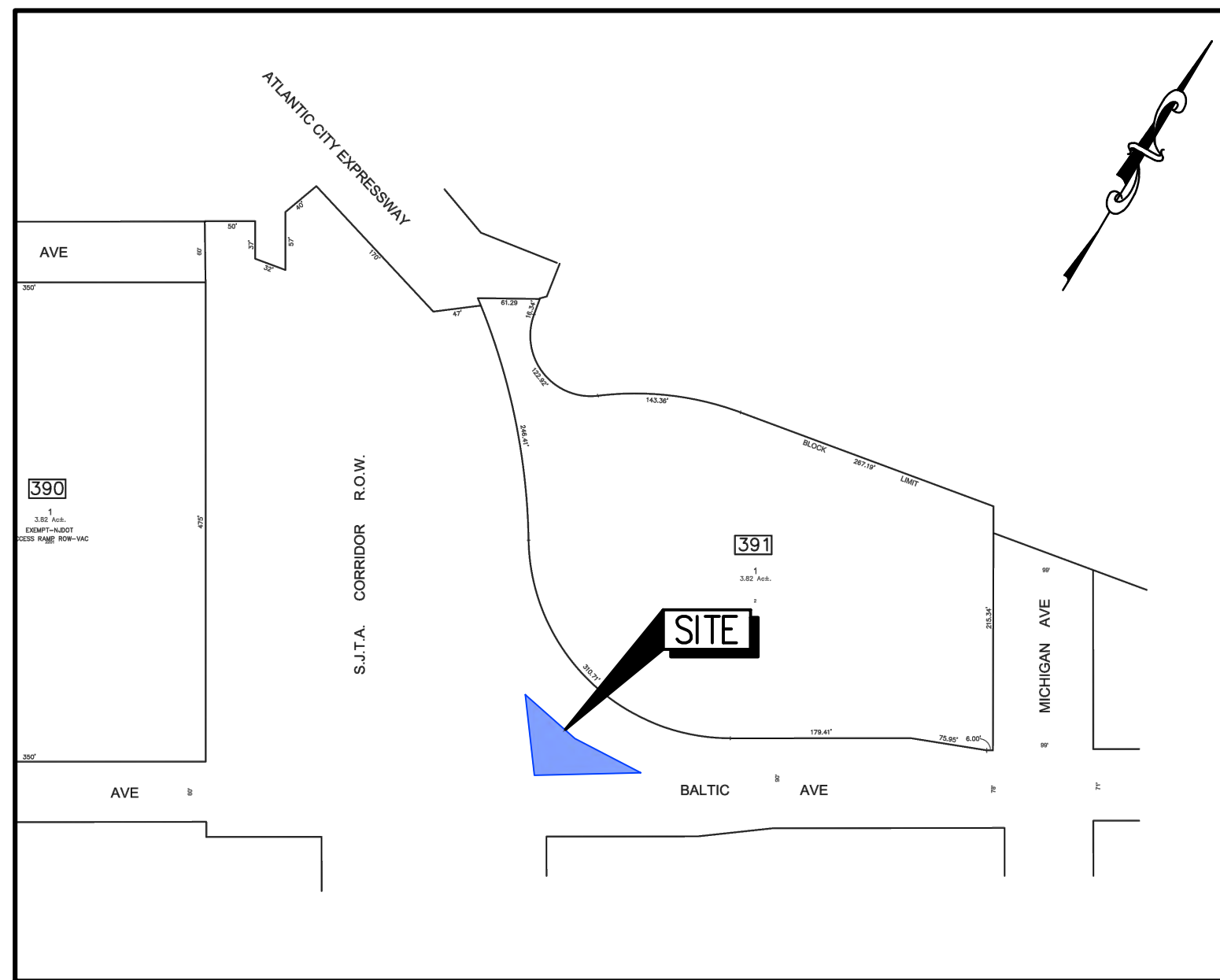

OFFICIAL TAX MAP CITY OF ATLANTIC CITY

SCALE: 1" = 150'

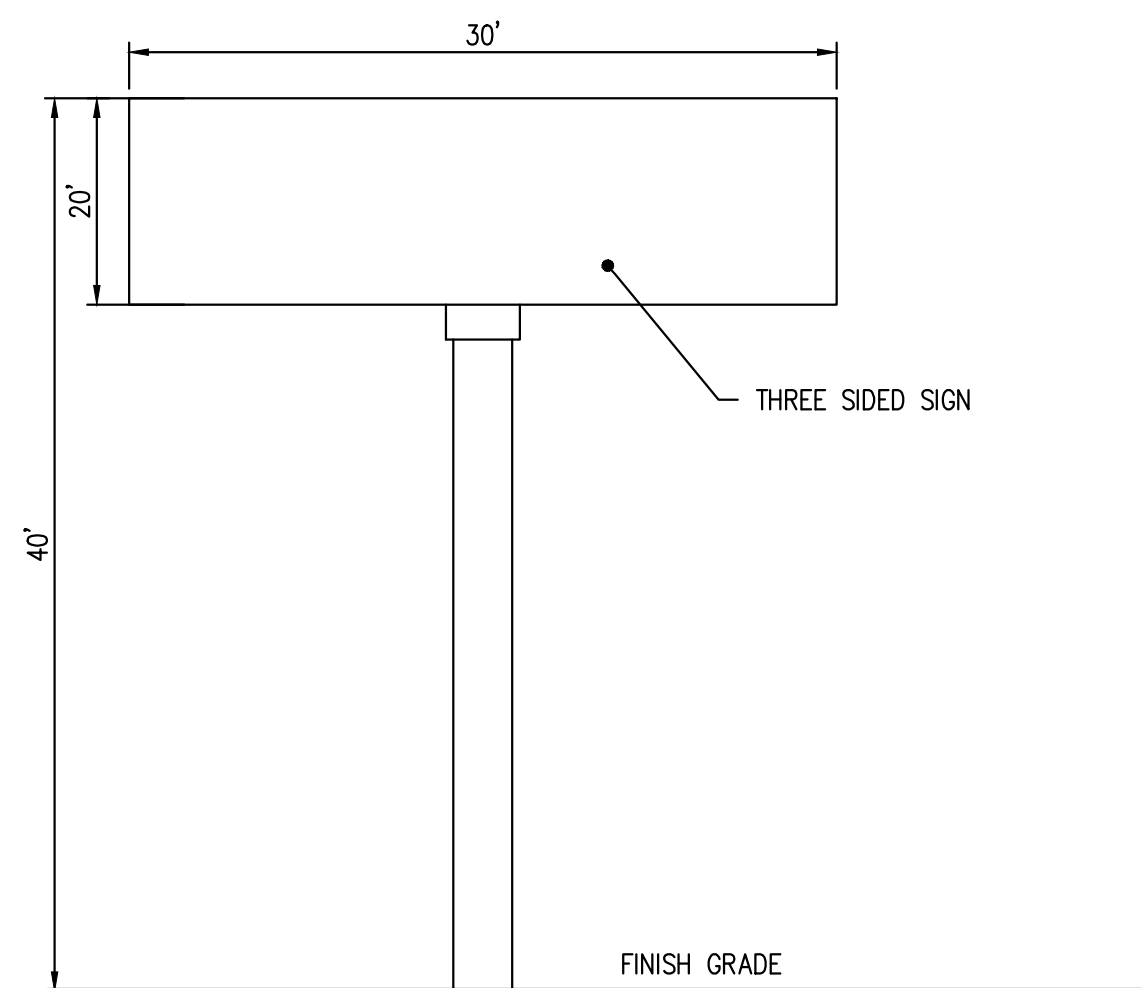

ADVERTISING SIGN DETAIL

SCALE: N.T.S.

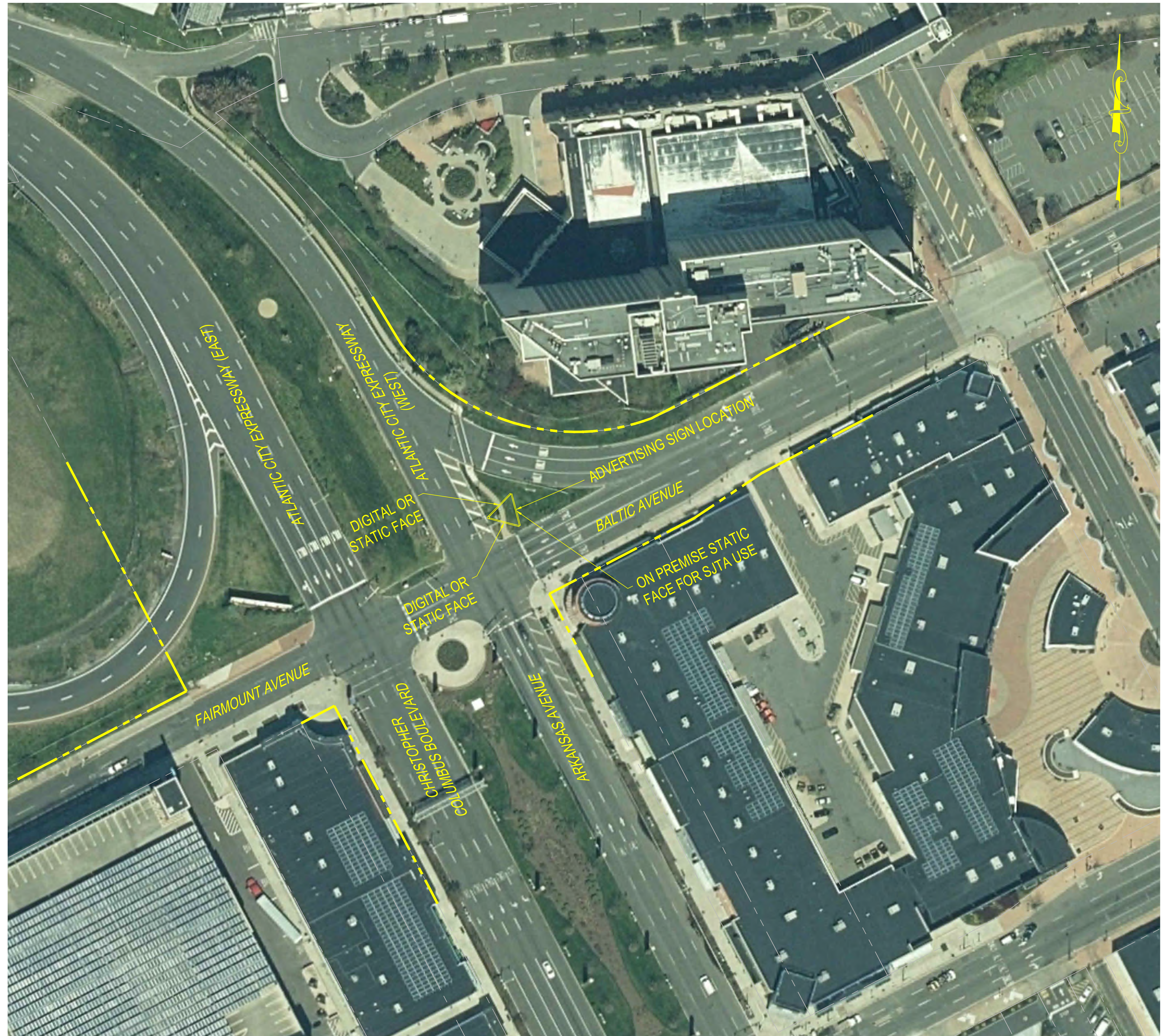

NOTES:

1. EXISTING CONDITIONS TAKEN FROM GIS TAX MAP BOUNDARY INFORMATION
2. AERIAL MAP SHOWN IS 2020 AND IS AS TAKEN FROM NEW JERSEY GEOGRAPHIC INFORMATION NETWORK

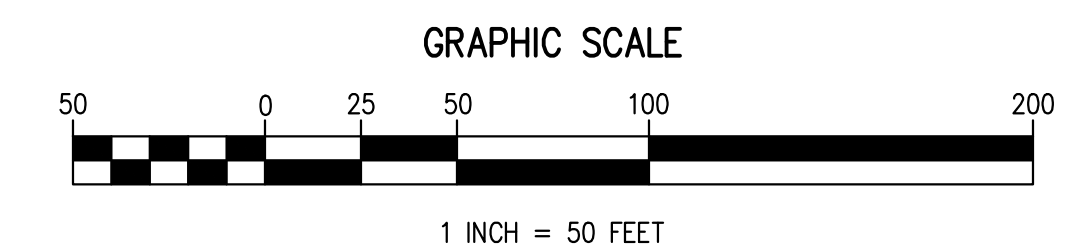

EXISTING UTILITY INFORMATION SHOWN ON THESE PLANS IS FOR INFORMATION ONLY. THE ENGINEER HAS CONDUCTED VISUAL SURVEYS AND THE LOCATION, DEPTH, AND CHARACTERISTICS OF UTILITIES SHOWN ARE BASED ON THESE SURVEYS. THE ENGINEER HAS NOT CONDUCTED A UTILITY LOCATING SURVEY. THE CONTRACTOR SHALL VERIFY THE LOCATION AND DEPTH OF UTILITIES PRIOR TO CONSTRUCTION. THE CONTRACTOR SHALL BE RESPONSIBLE FOR OBTAINING NECESSARY PERMITS AND FOR CONDUCTING A UTILITY LOCATING SURVEY PRIOR TO CONSTRUCTION. THE CONTRACTOR SHALL BE RESPONSIBLE FOR OBTAINING NECESSARY PERMITS AND FOR CONDUCTING A UTILITY LOCATING SURVEY PRIOR TO CONSTRUCTION. THE CONTRACTOR SHALL BE RESPONSIBLE FOR OBTAINING NECESSARY PERMITS AND FOR CONDUCTING A UTILITY LOCATING SURVEY PRIOR TO CONSTRUCTION.

811
Know what's below.
Call before you dig.

ALL DOCUMENTS PREPARED BY SCIULLO ENGINEERING SERVICES, LLC ARE INSTRUMENTS OF SERVICE. THE CLIENT AGREES TO HOLD SCIULLO ENGINEERING SERVICES, LLC HARMLESS FROM AND AGAINST ALL LIABILITY OR LEGAL EXPENSE TO SCIULLO ENGINEERING SERVICES, LLC AND SHALL BE RESPONSIBLE FOR OBTAINING NECESSARY PERMITS AND FOR CONDUCTING A UTILITY LOCATING SURVEY PRIOR TO CONSTRUCTION. THE CONTRACTOR SHALL BE RESPONSIBLE FOR OBTAINING NECESSARY PERMITS AND FOR CONDUCTING A UTILITY LOCATING SURVEY PRIOR TO CONSTRUCTION.

JASON T. SCIULLO, P.E., P.P.
PROFESSIONAL ENGINEER, NEW JERSEY LICENSE NO. 246204586000
PROFESSIONAL PLANNER, NEW JERSEY LICENSE NO. 3510026400

www.sciulloengineering.com
j.sciullo@sciulloengineering.com

SE SCIULLO ENGINEERING SERVICES, LLC
137 SOUTH NEW YORK AVENUE, SUITE 2
ATLANTIC CITY, NEW JERSEY 08401
PHONE: (609) 300-5171
www.sciulloengineering.com
NJ CERTIFICATE OF AUTHORIZATION NO. 246A28230700

SJTA OUTDOOR ADVERTISING SIGN
SJTA & BALTIC AVENUE R.O.W.
CITY OF ATLANTIC CITY, ATLANTIC COUNTY, NEW JERSEY

ADVERTISING SIGN LOCATION PLAN

GARDEN STATE OUTDOOR
1555 ZION ROAD, SUITE 203
NORTHFIELD, NEW JERSEY 08225

PROJECT NO.	GSO 017.01	DRAWING NO.	C2701
SCALE	AS SHOWN	SHEET	1 OF 1
DATE	12/17/2024	ISSUE NO.	1
BY	JTS	APPR.	
INITIAL RELEASE		SUBMISSION/REVISION	